

POMPA CON FRIZIONE MAGNETICA

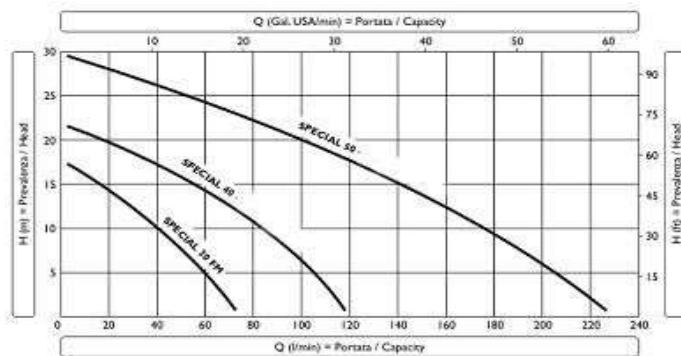

Tipo Type	Codice/Code		Materiale Material	Peso (kg) Weight	Giri/min Rpm	H (m)=Prevalenza / Head - Q (lt/min)=Portata / Capacity												
	FM 12V	FM 24V				0	5	10	12	15	18	22	28	30	H			
Special 30 FM	0957	0958	Bronzo	9,8	1400	75	60	40	30	15	0							
Special 40 FM	0959	0960	Bronzo	10,3	1400	120	110	85	80	55	45	0						
Special 50 FM	0961	0962	Bronzo	16,1	1400	230	210	175	155	140	12							

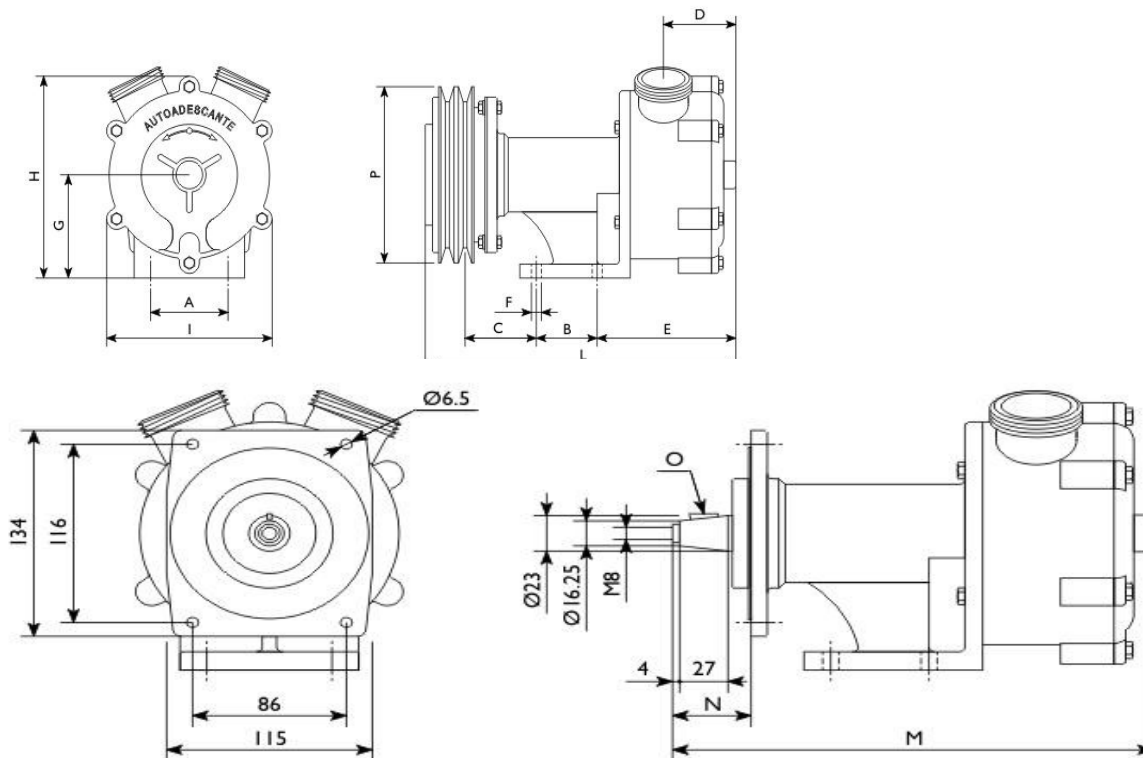

Tipo Type	Raccordi Pipe fit.	Dimensioni (mm) / Dimensions (mm)													
		A	B	C	D	E	F	G	H	I	L	M	N	O (*)	P (**)
Special 30 FM	Ø 30-35	70	55	68	50	103	Ø8,5	89	175	150	265	245	41	4x6,5	Ø 152x2A
Special 40 FM	Ø 40-45	70	55	68	67	128	Ø8,5	89	175	150	288	268	41	4x6,5	Ø 152x2A
Special 50 FM	Ø 50	70	55	94	90	160	Ø9	107	210	185	345	325	41	4x6,5	Ø 152x2A

(*) A-UNI 6606 (***) ISO R 52-253